

Standard Equipment

- ✓ Skip fitted to mount self-loading shovel
- ✓ Sealed wheel bearings to prevent ingress of dirt
- ✓ Hardened driving wheels for longer life
- ✓ STCS (Self Tension Crawler System)

Applications

The Taurus 500 mini-dumper is a highly agile and versatile machine, ideal for transporting and moving various kinds of materials around the building and road construction sites and in places that are difficult to access. Thanks to the 690 mm undercarriage with large-size sprocket and 3 rollers on either side, Taurus 500 is perfectly at home on all kinds of terrain, including steep gradients. The travel speed of 0-2.5 km/h guarantees maximum operating capability and top grade performance.

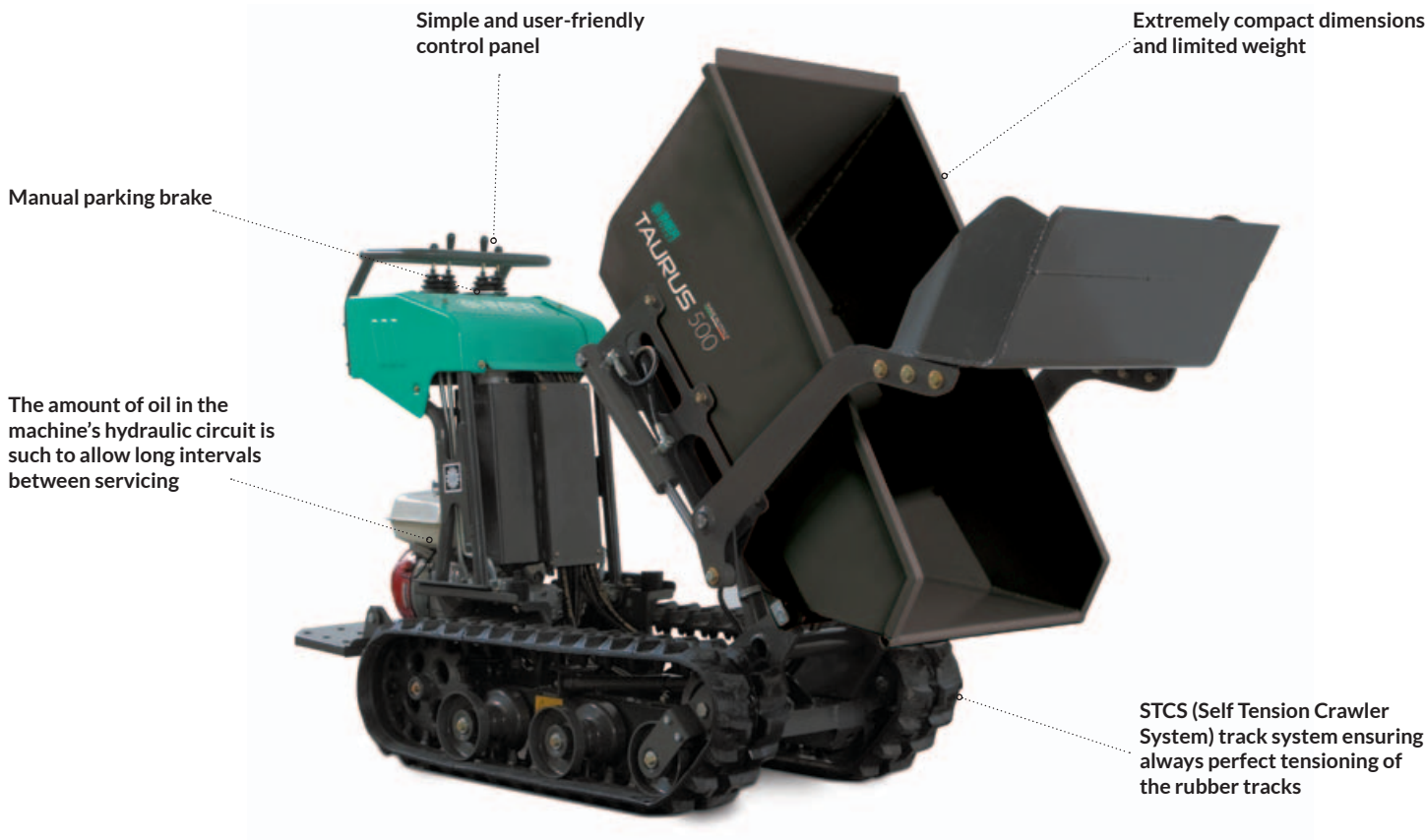

CODE	DESCRIPTION
1108004	TAURUS 500 CP-B5 Honda GX200 petrol engine, skip and self-loading shovel



Engine

The Taurus 500 mini-dumper has a Honda 4.7 kW rpm petrol engine with pull-cord starter.

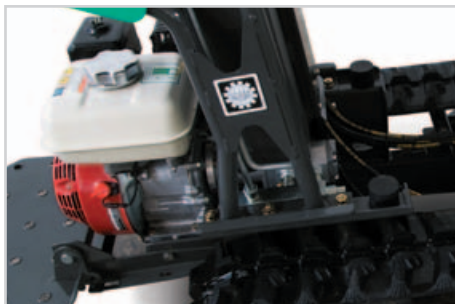

Safety and Standards

The engine is a low noise version which meets established noise pollution standards. The engine is mounted on vibration dampers to significantly reduce the amount of vibration transmitted.



Limited Weight

The Taurus 500 mini-dumper has a total weight of only 345 kg, complete with skip and self-loading shovel. Designed to satisfy all worksite requirements.



Full accessibility

The amount of oil in the machine's hydraulic circuit is such to allow long intervals between servicing. All parts requiring inspection and servicing are easily accessible.



STCS track tensioning

The innovative STCS (Self Tension Crawler System) track system ensures the rubber tracks are always perfectly tensioned, easily adjusted via a bolt on the lower carriage.



Parking brake

The manual parking brake prevents the drive from running by mechanically locking the LH wheel.

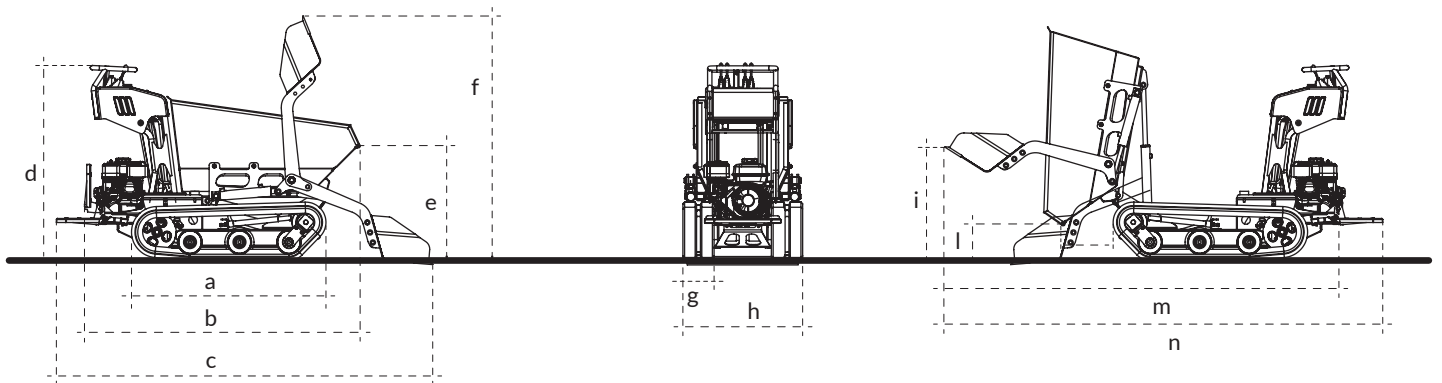

DIMENSIONS (mm)

a	b	c	d	e	f	g	h	i	l	m	n
1141	1589	2167	1132	674	1433	180	690	671	220	2371	2533

TAURUS 500 CP-B5

Engine		Honda GX200 petrol
Engine power	kW / rpm	4.7 / 3600
Starter		pull-cord
Operating load	kg	500
Skid capacity	m ³	0.22
Self-loading shovel		double arm
Speed	km / h	0 / 2.5
Max allowed slope when empty (guide with operator on the ground, where applicable)		20° - 36% *
Max allowed slope when loaded (guide with operator on the ground, where applicable)		11° - 20% *
Controls		DCS (Direct Control System)
Hydraulic tank capacity	L	15
Traction motor		orbital
Machine weight with skip and shovel	kg	345

(*) variable based on the configuration